

Технические характеристики фрез серии «Future Mill»

Выбор оптимального угла врезания для минимального диаметра винтовой линии DH min

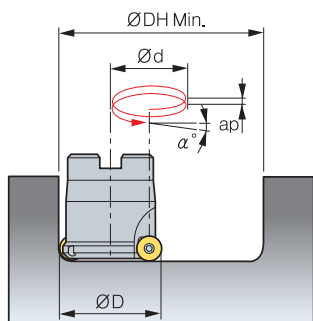

- ØD = Tool Dia.(мм), ØDH Min, Max = Min, Max diameter(мм)
- Ød = Tool Path (мм)
- ØDH Min (Min diameter) = $\text{ØD} \times 2$ - СМП size, ØDH Max (Max diameter) = $\text{ØD} \times 2$ - 2
- Ød (tool path) = ØDH Min, Max - ØD

Обозначение фрезы	Количество СМП	Диаметр фрезы	ØDH Min	Ød	Угол врезания (α°)									
					Шаг винтовой линии ap, мм									
					1	2	2.5	3	3.5	4	5	6	8	
FMR 1000	5	08	11	3	6.11	12.35	15.57	-	-	-	-	-	-	-
	5	10	15	5	3.65	7.34	7.34	-	-	-	-	-	-	-
	5	12	19	7	2.61	5.23	5.23	-	-	-	-	-	-	-
	5	15	25	10	1.83	3.65	3.65	-	-	-	-	-	-	-
FMR 1500	6	10	14	4	4.57	9.20	9.20	13.95	-	-	-	-	-	-
	6	12	18	6	3.04	6.11	6.11	9.20	-	-	-	-	-	-
	6	16	26	10	1.83	3.65	3.65	5.49	-	-	-	-	-	-
	6	20	34	14	1.30	2.61	2.61	3.92	-	-	-	-	-	-
FMR 2000	7	15	23	8	2.28	4.57	4.57	6.88	8.04	-	-	-	-	-
	7	20	33	13	1.40	2.81	2.81	4.22	4.92	-	-	-	-	-
FMR 2500	8	16	24	8	2.28	4.57	4.57	6.88	8.04	9.20	-	-	-	-
	8	20	32	12	1.52	3.04	3.04	4.57	5.34	6.11	-	-	-	-
	8	25	42	17	1.07	2.15	2.15	3.22	3.76	4.30	-	-	-	-
FMR 3000	10	25	40	15	1.22	2.43	2.43	3.65	4.27	4.88	6.11	-	-	-
	10	32	54	22	0.83	1.66	1.66	2.49	2.91	3.32	4.15	-	-	-
	10	40	70	30	0.61	1.22	1.22	1.83	2.13	2.43	3.04	-	-	-
	10	50	90	40	0.46	0.91	0.91	1.37	1.60	1.83	2.28	-	-	-
	10	63	116	53	0.34	0.69	0.69	1.03	1.21	1.38	1.72	-	-	-
	10	80	150	70	0.26	0.52	0.52	0.78	0.91	1.04	1.30	-	-	-
	10	100	190	90	0.20	0.41	0.41	0.61	0.71	0.81	1.01	-	-	-
FMR 4000	12	32	52	20	0.91	1.83	1.83	2.74	3.20	3.65	4.57	5.49	-	-
	12	40	68	28	0.65	1.30	1.30	1.96	2.28	2.61	3.26	3.92	-	-
	12	50	88	38	0.48	0.96	0.96	1.44	1.68	1.92	2.40	2.88	-	-
	12	63	114	51	0.36	0.72	0.72	1.07	1.25	1.43	1.79	2.15	-	-
	12	80	148	68	0.27	0.54	0.54	0.81	0.94	1.07	1.34	1.61	-	-
	12	100	188	88	0.21	0.41	0.41	0.62	0.73	0.83	1.04	1.24	-	-
	12	125	238	113	0.16	0.32	0.32	0.48	0.57	0.65	0.81	0.97	-	-
FMR 5000	16	40	64	24	0.76	1.52	1.52	2.28	2.66	3.04	3.81	4.57	6.11	-
	16	50	84	34	0.54	1.07	1.07	1.61	1.88	2.15	2.69	3.22	4.30	-
	16	63	110	47	0.39	0.78	0.78	1.16	1.36	1.55	1.94	2.33	3.11	-
	16	80	144	64	0.29	0.57	0.57	0.86	1.00	1.14	1.43	1.71	2.28	-
	16	100	184	84	0.22	0.43	0.43	0.65	0.76	0.87	1.09	1.30	1.74	-
	16	125	234	109	0.17	0.33	0.33	0.50	0.59	0.67	0.84	1.00	1.34	-
FMR 6000	20	50	80	30	0.61	1.22	1.22	1.83	2.13	2.43	3.04	3.65	4.88	6.11
	20	63	106	43	0.42	0.85	0.85	1.27	1.49	1.70	2.12	2.55	3.40	4.25
	20	80	140	60	0.30	0.61	0.61	0.91	1.06	1.22	1.52	1.83	2.43	3.04
	20	100	180	80	0.23	0.46	0.46	0.68	0.80	0.91	1.14	1.37	1.83	2.28
	20	125	230	105	0.17	0.35	0.35	0.52	0.61	0.70	0.87	1.04	1.39	1.74
	20	160	300	140	0.13	0.26	0.26	0.39	0.46	0.52	0.65	0.78	1.04	1.30

Технические характеристики фрез серии «Future Mill»



Фрезерование

Е