

Дисковые прорезные регулируемые фрезы E

FC (Трехсторонние фрезы)

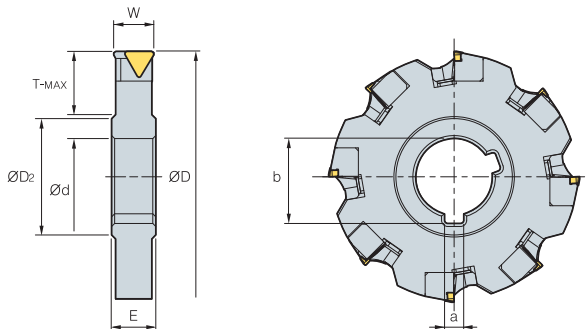

• AR : 5°
• RR : 0°

(мм)

Обозначение		ØD	W	T-MAX	Ød	E	a	b	ØD2	СМП
FC 08010	6	80	10	17.0	25.4	12	6.35	28	41.5	TPCN1103PPN
10012	8	100	12	24.0	31.75	14	7.92	35.2	48	TPCN1103PPN
12512	10	125	12	31.5	38.1	14	9.52	42.3	58	TPCN1103PPN
12520	8	125	20	31.5	38.1	22	9.52	42.3	58	TPCN1603PPN
16012	12	160	12	49.0	38.1	14	9.52	42.3	58	TPCN1103PPN
16016	12	160	16	49.0	38.1	18	9.52	42.3	58	TPCN1103PPN
16018	10	10	18	49.0	38.1	20	9.52	42.3	58	TPCN1603PPN
16020	10	10	20	49.0	38.1	22	9.52	42.3	58	TPCN1603PPN
20022	12	200	22	61.0	50.8	24	12.7	55.8	72	TPCN1603PPN
25024	16	250	24	81.0	50.8	26	12.7	55.8	84	TPCN1603PPN
31524	16	315	24	113.5	50.8	26	12.7	55.8	84	TPCN1603PPN

Применяемые СМП

TPCN



Обозначение	Тв. сплав с покрытием								Кермет		Тв. сплав				Стр.			
	NCM325	NCM335	NC5330	PC3500	PC5300	PC3545	PC9530	PC6510	PC215K	PD2000	CN2000	CN20	CN30	H01		G10	ST30A	ST20
TPCN 1103PPN																		E20
1603PPN	●							●							●			

Применяемые оправки

Обозначение	Оправка	
FC 08010	BT40-SCA27-75/120	BT50-SCA27-90/135
10012	BT40-SCA32-105	BT50-SCA32-90/135
12512	-	BT50-SCA40-90/135
12520	-	BT50-SCA40-90/135
16012	-	BT50-SCA40-90/135
16018	-	BT50-SCA40-90/135
16020	-	BT50-SCA40-90/135
20022	-	-
25024	-	-
31524	-	-

Рекомендуемые режимы резания

Обрабатываемые материалы	Режимы резания		Марка сплава
	Vp, м/мин	Sz, мм/зуб	
P	150 ~ 250	0.10 ~ 0.25	NCM325 PC3500 ST30A
	120 ~ 200	0.10 ~ 0.30	
	100 ~ 150	0.10 ~ 0.30	
M	80 ~ 180	0.10 ~ 0.25	PC9530 ST30A
	80 ~ 150	0.10 ~ 0.30	
K	130 ~ 200	0.10 ~ 0.35	PC6510 G10
	100 ~ 150	0.10 ~ 0.40	

Комплектующие



LFC2R/L · LFC3R/L	WFC2N · WFC3N	DHA0617	MHB0310	HW30L
LFC2R/L-1*	WFC2N-1*	DHA0815	MHB0410	HW40L

* FC08010

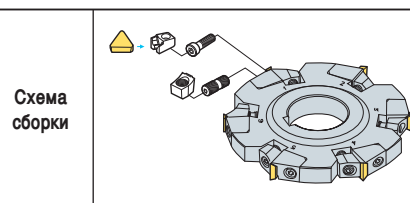

Применяемые СМП смотреть на стр. E20

Присоединительные размеры смотреть на стр. E277~E279

● : Наличие на складе

