

Дисковые пререзные (отрезные) сборные фрезы E

SPS

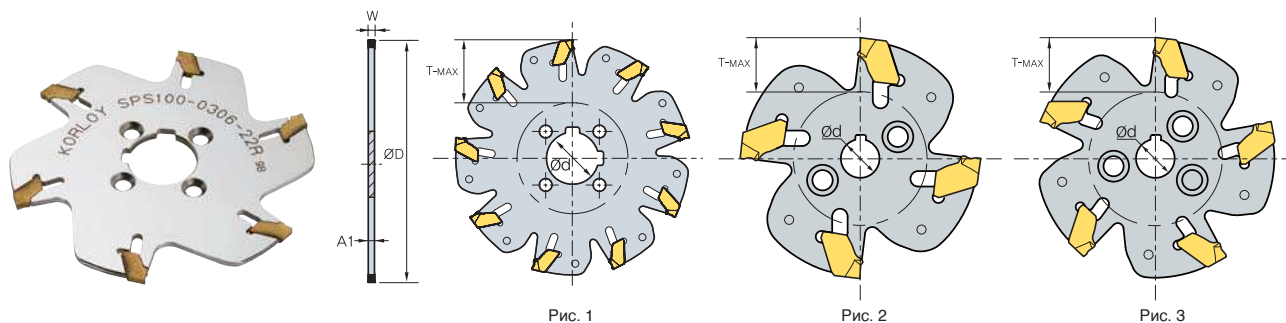

Обозначение	ØD	W	T-МАХ	Ød	A1	Рис.	смп	Оправки и планшайбы (мм)		
								WS	DF	
SPS 050-0204-08R	4	50	2.2	11	8	2	SPFN 200 ()	WS2528-M4	-	
063-0205-10R	5	63	2.2	15.5	10	3		WS2532-M5	-	
080-0207-22R/F	7	80	2.2	20(17)	22	1.8		1	WS3240-M5	DF22-46
100-0209-22R/F	9	100	2.2	30(27)	22	1.8		1	WS3240-M5	DF22-46
125-0211-32F	11	125	2.2	35	32	1.8		1	-	DF32-55
160-0214-32F	14	160	2.2	52.5	32	1.8		1	-	DF32-55
063-0305-10R	5	63	3	15.5	10	2.55		3	WS2532-M5	-
080-0307-22R/F	7	80	3	20(17)	22	2.55		1	WS3240-M5	DF22-46
100-0309-22R/F	9	100	3	30(27)	22	2.55		1	WS3240-M5	DF22-46
125-0311-32F	11	125	3	35	32	2.55		1	-	DF32-55
160-0314-32F	14	160	3	52.5	32	2.55	1	-	DF32-55	
200-0318-40F	18	200	3	60	40	2.55	1	-	DF40-80	
080-0406-22R/F	6	80	4	20(17)	22	3.4	1	SPFN 300 ()	WS3240-M5	DF22-46
100-0408-22R/F	8	100	4	30(27)	22	3.4	1	400	WS3240-M5	DF22-46
125-0410-32F	10	125	4	35	32	3.4	1	-	-	DF32-55
160-0413-32F	13	160	4	52.5	32	3.4	1	-	-	DF32-55
200-0417-40F	17	200	4	60	40	3.4	1	-	-	DF40-80

WS() () Оправки с хвостовиком Weldon

DF() () Планшайбы

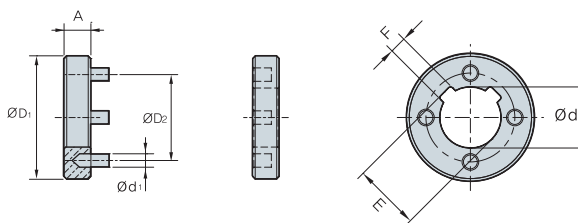
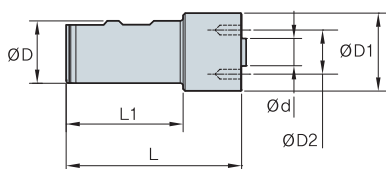

Обозначение	L	L1	D	D1	D2	d	Винт
WS2528-M4	110	85	25	28	18	8	РТКА0408
WS2532-M5	110	85	25	32	22	10	РТКА0515
WS3240-M5	120	90	32	40	32	22	РТКА0515

Обозначение	D1	D2	d	d1	A	E	F
DF22-46	46	32	22	5	10	24.1	6
DF32-55	55	45	32	6	10	34.8	8
DF40-80	80	63	40	11	12	43.5	10
DF50-110	110	80	50	14	14	53.6	12

Рекомендуемые режимы резания

Обрабатываемые материалы	Режимы резания		Марка сплава
	V _p , м/мин	S _z , мм/зуб	
P	150(100~200) 120(80~170)	0.13~0.25 0.10~0.17	PC3500 PC3545
M	160(120~200)	0.10~0.22	PC5300
K	110(70~150)	0.10~0.25	PC215K

