

FMRC(M)4000

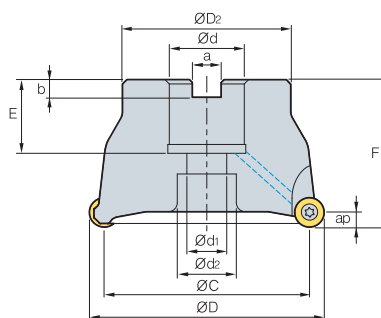

• AR : 5°
• RR : -5°

(MM)

Обозначение		ØD	ØC	ØD2	Ød	a	b	E	F	Ød1	Ød2	ap	
FMRC(M) 4050HRD	4	50	38	42	22	10.4	6.3	20	50	11	18	6.0	0.4
4063HRD	4	63	51	49	22	10.4	6.3	20	50	11	18	6.0	0.6
4063HRD-M	5	63	51	49	22	10.4	6.3	20	50	11	18	6.0	0.6
4080HRD	5	80	68	57	25.4(27)	9.5(12.4)	6(7.0)	25(23)	50(50)	14	20	6.0	1.0
4080HRD-M	6	80	68	57	25.4(27)	9.5(12.4)	6(7.0)	25(23)	50(50)	14	20	6.0	1.0
4100HRD	6	100	88	67	31.75(32)	12.7(14.4)	8(8.0)	33(25)	63(50)	18	26	6.0	1.9(1.5)
4100HRD-M	7	100	88	67	31.75(32)	12.7(14.4)	8(8.0)	33(25)	63(50)	18	26	6.0	1.9(1.5)
4125HRD	7	125	113	87	38.1(40)	15.9(16.4)	10(9.0)	35(29)	63(63)	22	32	6.0	3.0
4125HRD-M	8	125	113	87	38.1(40)	15.9(16.4)	10(9.0)	35(29)	63(63)	22	32	6.0	3.0

Примечание) Это вообще, что вы измеряете внутренний диаметр когда диаметр FMRC / FMRCM является Ø40 ~ Ø63

• () Метрическая система

Применяемые СМП

Обозначение	RDKT-MF			RDKT-MM						RDCT-MA				Стр.				
	NCM825	NCM835	NC5330	PC3500	PC5300	PC5945	PC9530	PC6510	PC215K	PD2000	CN2000	CN20	CN30		H01	G10	ST30A	ST20
RDCT 1204M0-MA														●				E12
RDKT 1204M0-MF				●	●	●	●	●										E13
1204M0-MM	●	●	●	●	●	●	●	●										

Применяемые оправки

Обозначение	Ød	Оправка с хвостовиком BT
FMRC(M) 4050HRD	22	BT□□-FMC22-□□
4063HRD		
4063HRD-M		
4080HRD	25.4	BT□□-FMA / FMB25.4-□□
4080HRD-M	27	BT□□-FMB / FMC27-□□
4100HRD	31.75	BT□□-FMA31.75-□□
4100HRD-M	32	BT□□-FMC32-□□
4125HRD	38.1	BT□□-FMA / FMB38.1-□□
4125HRD-M	40	BT□□-FMB / FMC40-□□

Комплектующие

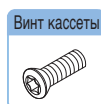

FTKA0410



TW15S