

Дисковые прорезные регулируемые фрезы E

SPP(M)

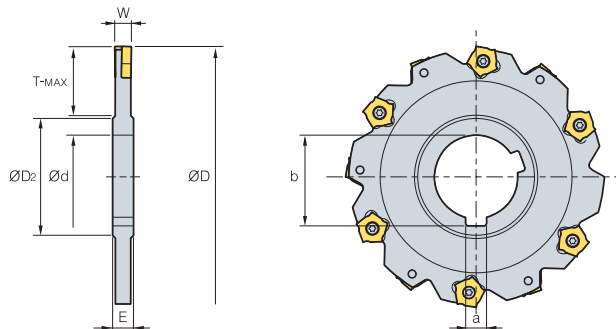

• AR : -2°
• RR : -28°

(мм)

Обозначение	ØD	W	T-MAX	Ød	a	b	E	ØD2	СМП	Винт	Ключ	
SPP(M) 080-04	8	80	4	20	25.4(27)	6.35(7)	28.04(29.8)	8	40	PNEJ1223N	PTMA0403F	TW15S
080-05	8	80	5	20	25.4(27)	6.35(7)	28.04(29.8)	8	40	PNEJ1230N	PTMA0404F	TW15S
080-06	8	80	6	20	25.4(27)	6.35(7)	28.04(29.8)	8	40	PNEJ1235N	PTMA0405F	TW15S
100-04	10	100	4	24	31.75(32)	7.94(8)	35.18(34.8)	8	47	PNEJ1223N	PTMA0403F	TW15S
100-05	10	100	5	24	31.75(32)	7.94(8)	35.18(34.8)	8	47	PNEJ1230N	PTMA0404F	TW15S
100-06	10	100	6	25	31.75(32)	7.94(8)	35.18(34.8)	8	47	PNEJ1235N	PTMA0405F	TW15S
100-07	10	100	7	25	31.75(32)	7.94(8)	35.18(34.8)	10	47	PNEJ1240N	PTMA0406F	TW15S
100-08	10	100	8	25	31.75(32)	7.94(8)	35.18(34.8)	10	47	PNEJ1245N	PTKA0407F	TW15S
100-09	10	100	9	25	31.75(32)	7.94(8)	35.18(34.8)	12	47	PNEJ1250N	PTKA0408F	TW15S
100-10	10	100	10	25	31.75(32)	7.94(8)	35.18(34.8)	12	47	PNEJ1255N	PTKA0409F	TW15S
125-04	12	125	4	30	38.1(40)	9.53(10)	42.32(43.5)	8	56	PNEJ1223N	PTMA0403F	TW15S
125-05	12	125	5	32	38.1(40)	9.53(10)	42.32(43.5)	8	56	PNEJ1230N	PTMA0404F	TW15S
125-06	12	125	6	32	38.1(40)	9.53(10)	42.32(43.5)	8	56	PNEJ1235N	PTMA0405F	TW15S
125-07	12	125	7	32	38.1(40)	9.53(10)	42.32(43.5)	10	56	PNEJ1240N	PTMA0406F	TW15S
125-08	12	125	8	32	38.1(40)	9.53(10)	42.32(43.5)	10	56	PNEJ1245N	PTKA0407F	TW15S
125-09	12	125	9	32	38.1(40)	9.53(10)	42.32(43.5)	12	56	PNEJ1250N	PTKA0408F	TW15S
125-10	12	125	10	32	38.1(40)	9.53(10)	42.32(43.5)	12	56	PNEJ1255N	PTKA0409F	TW15S
160-04	16	160	4	45	38.1(40)	9.53(10)	42.32(43.5)	8	66	PNEJ1223N	PTMA0403F	TW15S
160-05	16	160	5	45	38.1(40)	9.53(10)	42.32(43.5)	8	66	PNEJ1230N	PTMA0404F	TW15S
160-06	16	160	6	45	38.1(40)	9.53(10)	42.32(43.5)	8	66	PNEJ1235N	PTMA0405F	TW15S
160-07	16	160	7	45	38.1(40)	9.53(10)	42.32(43.5)	10	66	PNEJ1240N	PTMA0406F	TW15S
160-08	16	160	8	45	38.1(40)	9.53(10)	42.32(43.5)	10	66	PNEJ1245N	PTKA0407F	TW15S
160-09	16	160	9	45	38.1(40)	9.53(10)	42.32(43.5)	12	66	PNEJ1250N	PTKA0408F	TW15S
160-10	16	160	10	45	38.1(40)	9.53(10)	42.32(43.5)	12	66	PNEJ1255N	PTKA0409F	TW15S
160-11	16	160	11	45	38.1(40)	9.53(10)	42.32(43.5)	14	66	PNEJ1260N	PTKA0410F	TW15S
160-12	16	160	12	45	38.1(40)	9.53(10)	42.32(43.5)	14	66	PNEJ1265N	PTKA0411F	TW15S
160-13	16	160	13	45	38.1(40)	9.53(10)	42.32(43.5)	16	66	PNEJ1270N	PTKA0412F	TW15S
160-14	16	160	14	45	38.1(40)	9.53(10)	42.32(43.5)	16	66	PNEJ1275N	PTKA0413F	TW15S
200-06	18	200	6	60	50.8(50)	12.7(12)	55.83(53.5)	8	70	PNEJ1235N	PTMA0405F	TW15S
200-07	18	200	7	60	50.8(50)	12.7(12)	55.83(53.5)	10	70	PNEJ1240N	PTMA0406F	TW15S
200-08	18	200	8	60	50.8(50)	12.7(12)	55.83(53.5)	10	70	PNEJ1245N	PTKA0407F	TW15S
200-09	18	200	9	60	50.8(50)	12.7(12)	55.83(53.5)	12	70	PNEJ1250N	PTKA0408F	TW15S
200-10	18	200	10	60	50.8(50)	12.7(12)	55.83(53.5)	12	70	PNEJ1255N	PTKA0409F	TW15S
200-11	18	200	11	60	50.8(50)	12.7(12)	55.83(53.5)	14	70	PNEJ1260N	PTKA0410F	TW15S
200-12	18	200	12	60	50.8(50)	12.7(12)	55.83(53.5)	14	70	PNEJ1265N	PTKA0411F	TW15S
200-13	18	200	13	60	50.8(50)	12.7(12)	55.83(53.5)	16	70	PNEJ1270N	PTKA0412F	TW15S
200-14	18	200	14	60	50.8(50)	12.7(12)	55.83(53.5)	16	70	PNEJ1275N	PTKA0413F	TW15S

• () Метрическая система

Применяемые оправки

Обозначение	Оправка		
	BT30	BT40	BT50
SPP 080-04~06	BT30-SCA25.4-60	BT40-SCA25.4-75/120	BT50-SCA25.4-90/135
100-04~10	-	BT40-SCA31.75-105	BT50-SCA31.75-90/135
125-04~09	-	-	BT50-SCA38.1-90/135
160-04~14	-	-	BT50-SCA38.1-90/135
200-06~14	-	-	-
SPPM 080-04~06	-	BT40-SCA27-75/120	BT50-SCA27-90/135
100-04~10	-	BT40-SCA32-105	BT50-SCA32-90/135
125-04~09	-	-	BT50-SCA40-90/135
160-04~14	-	-	BT50-SCA40-90/135
200-06~14	-	-	-

Рекомендуемые режимы резания

Обрабатываемые материалы	Режимы резания		Марка сплава
	Vp, м/мин	Sz, мм/зуб	
P	150 ~ 250	0.10 ~ 0.25	NCM325 PC3500 ST30A
	120 ~ 200	0.10 ~ 0.30	
	100 ~ 150	0.10 ~ 0.30	
M	80 ~ 180	0.10 ~ 0.25	PC9530 ST30A
	80 ~ 150	0.10 ~ 0.30	
K	130 ~ 200	0.10 ~ 0.35	PC6510 G10
	100 ~ 150	0.10 ~ 0.40	

Система обозначения

S	P	P	160	-	06	R
Вид обработки (S отрезание)	Вид посадочного отверстия (P: отверстие со шпоночным пазом, B: цилиндр со шпоночным пазом на торце)		Диаметр фрезы(ØD)		Ширина реза (W)	Исполнение фрезы (L левое / R правое)
	Форма СМП (P пятигранная пластина)					

Применяемые СМП смотреть на стр. E12

Присоединительные размеры смотреть на стр. E270~E272

