

## Чистовая обработка (Внутреннее нарезание зубьев)

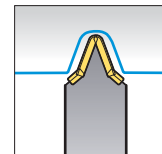
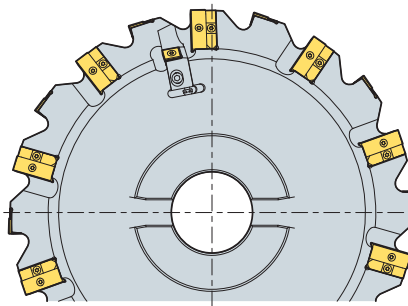
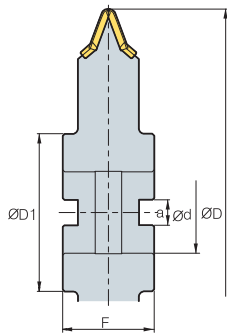

								(мм)
m		$\varnothing D$	$\varnothing d$	$\varnothing D_1$	a	F		
6	20	400	80	155	25	90		
8	20	400	80	155	25	90		
10	20	400	80	155	25	90		
12	20	400	80	155	25	90		
14	20	400	80	155	25	90		
16	20	400	80	155	25	90		
18	20	400	80	155	25	90		
20	20	400	80	155	25	90		
22	20	400	80	155	25	90		
24	20	400	80	155	25	90		

## Применяемые СМП

Форма	Обозначение	Тв. сплав с покрытием				Тв. сплав		Геометрические размеры					Геометрия
		NC5330	PC9630	PC3500	PC5300	H01	G10	l	d	t	d <sub>1</sub>	R	
	M6			○	◎			19	14.3	5	5.5	2.25	
	M8			○	◎			27	14.3	5.4	5.5	3	
	M10			○	◎			29	14.3	6.35	5.5	3.75	
	M12			○	◎			33	14.3	6.35	5.5	4.5	
	M14			○	◎			39	14.3	6.35	5.5	5.25	
	M16			○	◎			43	14.3	7.94	5.5	6	
	M18			○	◎			50	14.3	7.94	5.5	6.75	
	M20			○	◎			54	14.3	9.53	5.5	7.5	
	M22			○	◎			57	14.3	9.53	5.5	8.25	
	M24			○	◎			64	14.3	9.53	5.5	9	
	SNEQ1507-C0.8			○	◎			15.875	15.875	7.94	-	-	

\* Возможны изменения геометрических размеров фрезы согласно требованиям заказчика